



# HAWK GAS STOVE

## **Installation and Servicing Instructions**

Please leave this instruction booklet with the user after the installation is complete. Leave the system ready for operation and instruct the user in the correct use of the appliance and operation of its controls.

Please refer to the appliance data plate for the specific model type.

# Contents

|  |           |
|--|-----------|
| <b>TECHNICAL DATA.....</b>                                   | <b>3</b>  |
| STOVE DIMENSIONS .....                                       | 3         |
| <b>INSTALLING THE APPLIANCE .....</b>                        | <b>4</b>  |
| PRE-INSTALLATION NOTES.....                                  | 4         |
| FLUE ARRANGEMENT .....                                       | 6         |
| ADDITIONAL AIR VENTING (GB ONLY) .....                       | 6         |
| OPENING THE STOVE DOOR.....                                  | 7         |
| GAS SUPPLY CONNECTIONS .....                                 | 7         |
| TESTING SUPPLY PRESSURE.....                                 | 8         |
| <b>INSTALLATION OF THE FIRE-BED INTO<br/>THE STOVE .....</b> | <b>8</b>  |
| FIRE-BED ARRANGEMENT'.....                                   | 9         |
| FITTING THE CERAMIC MATRIX .....                             | 9         |
| <i>Section A - Fitting the Loose Ceramic Coals.....</i>      | <i>10</i> |
| <i>Section B - Fitting the Loose Ceramic Logs.....</i>       | <i>12</i> |
| FITTING THE CANOPY – (OPTIONAL).....                         | 15        |
| TEST FOR SPILLAGE .....                                      | 16        |
| SPILLAGE MONITORING SYSTEM .....                             | 16        |
| <b>SERVICING INSTRUCTIONS .....</b>                          | <b>17</b> |
| SPARES LIST.....   | 18        |

**Please read these instructions carefully**

**It is important that your stove is correctly installed as Hunter  
Stoves Limited cannot accept responsibility for any fault  
arising through incorrect installation.**

# TECHNICAL DATA

|   | NATURAL GAS            |
|---|------------------------|
| Nominal Gas Pressure                      | 20mBar                 |
| Supply Gas Type/Category                  | G20/I <sub>2H</sub>    |
| Jet Type/Size                             | 82/260                 |
| Heat Input (Gross)<br>Full<br>Low         | 4.7kW<br>3.5kW         |
| Gas Flow Rate (m <sup>3</sup> /h)<br>Full | 0.42 m <sup>3</sup> /h |
| NO <sub>x</sub> Class                     | 4                      |
| Efficiency Class                          | 2                      |
| Countries of Destination                  | GB & IE Only           |

## Stove Dimensions

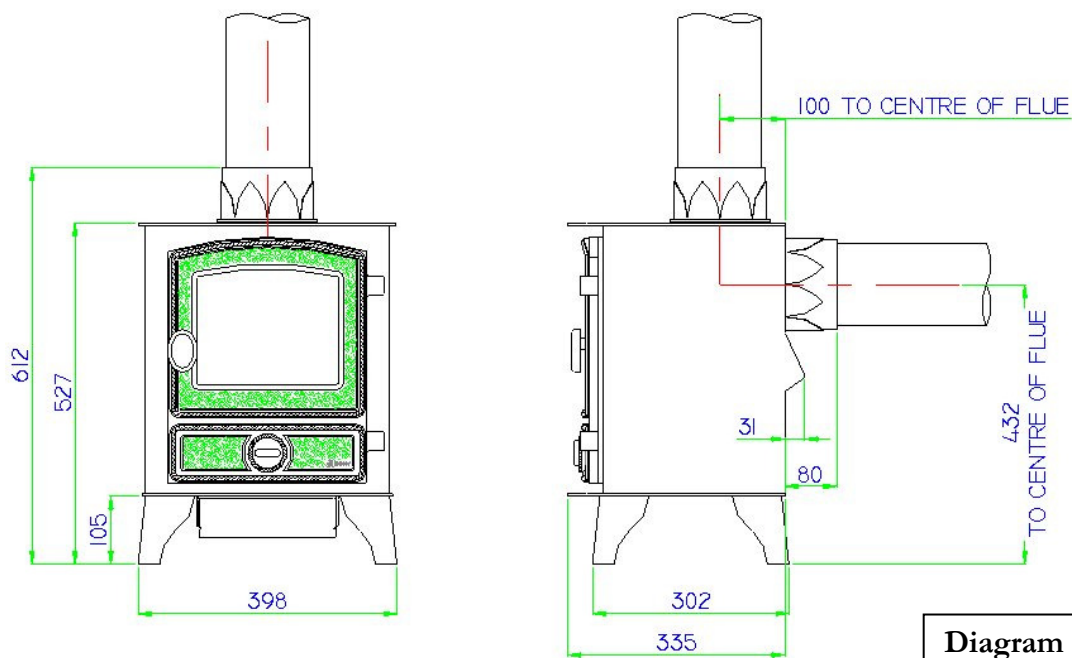

Diagram 1

# INSTALLING THE APPLIANCE

## Pre-installation notes

1. Check the stove data plate to establish the gas type required. The data plate can be found bolted to the inside of the door.  
Before installation check that the local distribution conditions, nature of the gas and pressure, and adjustment of the application are compatible.
2. This appliance is intended for use on a gas installation with a governed meter.
3. A **GAS SAFE REGISTERED INSTALLER** or equally recognised competent person must fit the appliance. That person is legally responsible for the safe installation of the appliance with due regard to all relevant local and national building regulations.
4. All outer surfaces of the stove excepting the gas control knob and valve cover flap are defined as working surfaces.

### **Installation site**

5. Any installation area previously used for a solid fuel fire or stove would probably be deemed suitable for the appliance.
6. It should be noted that heat given off from this appliance might affect articles placed close to it. Curtains should not be positioned above the appliance or within 300mm of the sides. Caution should also be taken sighting the appliance near to 'embossed' type wallpapers.
7. The appliance must be sited on a non-combustible hearth of minimum 12mm thickness.
8. The hearth should be edged or raised to prevent combustible floor finishes (e.g. Carpet) from being laid too close to the appliance.

### **Clearances**

9. For the relevant clearance distances for installing the appliance see diagram 2 on page 5.

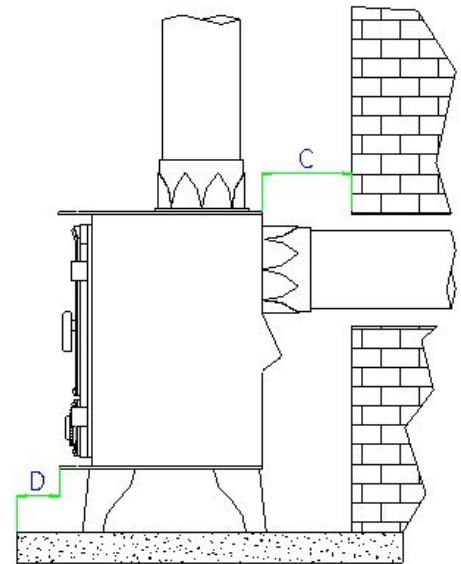
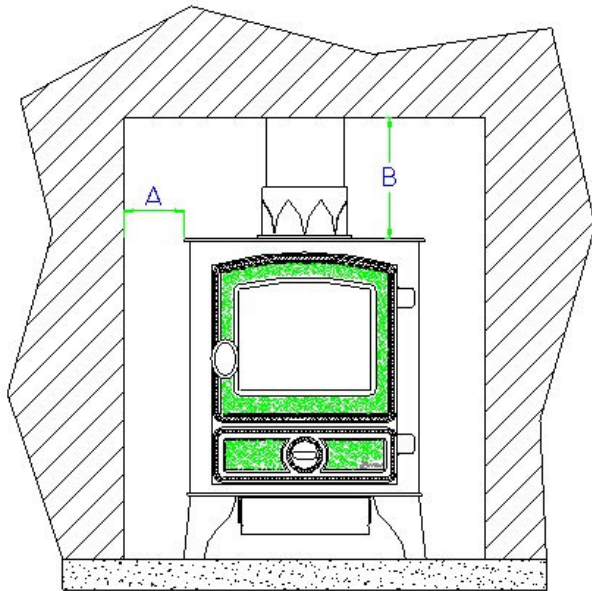

**Diagram 2**

**IMPORTANT NOTE!** Adequate clearance must be given between the appliance and the walls so that a satisfactory spillage test can be performed as detailed on page 16.

|          | <b>DIMENSION<br/>DESCRIPTION</b>                        | <b><u>MINIMUM CLEARANCE DISTANCES TO:</u></b> |                                     |
|----------|---|---|-------------------------------------|
|          |   | <b>COMBUSTIBLE<br/>MATERIAL</b>               | <b>NON-COMBUSTIBLE<br/>MATERIAL</b> |
| <b>A</b> | Side of stove to wall                                   | 150mm   | 100mm                               |
| <b>B</b> | Top of stove to underside of opening or shelf           | 250mm   | 200mm                               |
| <b>C</b> | Rear of stove to wall                                   | 150mm   | 100mm                               |
| <b>D</b> | Minimum distance for hearth to extend in front of stove | 50mm  | 50mm                                |

**Clearance Distances for Diagram 2**

## **Flue Arrangement**

**The GAS SAFE REGISTERED ENGINEER commissioned to install this appliance is wholly responsible for deciding the suitability of any flue arrangement to operate in conjunction with this gas appliance.**

The chimney or flue system that is to be fitted to the Hawk gas stove must comply with the current rules in force.

(The Hawk gas stove is also suitable for other specific class 2 installation arrangements: pre-cast flues, ridge-vent flues and pre-cast chimney block and with the relevant adaption, the appliance will operate in a closure plate type system.)

It is suggested to run flue pipe at least 615mm vertically from the unit before there are any changes in direction of the flue system. Wherever possible horizontal runs of the flue system should be avoided.

It is suggested that the flue has a minimum of 3 meters of vertical height. Please note for rear flue appliances it is recommended that the vertical flue run be established as soon as is practical from the rear flue exit. (Caution should be taken locating the exit of the flue as explained in 'The Building Regulations - Document J'.)

Before commencing any installation work the installing engineer must check that the flue is free from all blockages, the chimney should be given a precautionary clean, and finally the chimney should be smoke tested to ensure soundness. Additionally any flue dampers must be permanently fixed open or removed altogether.

The flue collar and flue blanking plate should be fitted to the stove using the supplied gaskets.

### **Additional Air Venting (GB Only)**

The supply gas heat input into the appliance is nominally less than 7kw, therefore under the directives of the current gas safety and use regulations (1995) No additional air vents are required in the room the appliance is situated.

## Opening the Stove Door

**NOTE! This appliance must never be used with the door open or removed.**

Before gaining access to the burner tray, first make sure that the stove is switched off and is cold. Now the cast iron door can be opened, this is secured in place by one fixing bolt.



Diagram 3

Firstly remove the door handle by turning anticlockwise. Keep turning until the handle is completely removed, as shown in diagram 3.



Diagram 4

The door-fixing bolt can then be removed using a 13mm spanner as shown in diagram 4.

## Gas Supply Connections

The appliance is supplied with an 8mm Bundy pipe and an 8mm compression elbow to allow easy connection to the mains gas supply. This gas supply pipe should incorporate a gas service isolation tap that is situated within 1 metre of the application.



Diagram 5

Diagram 5 shows the 8mm Bundy pipe being fitted to the gas inlet on the valve. The compression joint is tightened with a 14mm open-ended spanner.

## Testing Supply Pressure

***ALWAYS CLOSE TEST POINTS AFTER USE!***



The gas pressure at the appliance is measured with the appliance running at **full rate**. (For information on how to achieve 'full rate' read 'Lighting the main burner' in the 'Operating the Appliance' section of the User Instructions).

The test point should be opened with flat bladed screwdriver and is shown in diagram 6.

Diagram 6

Test Point

**Burner Gas Pressure should be:**

**Natural Gas@ 19mBars +/- 0.3mBar**

## INSTALLATION OF THE FIRE-BED INTO THE STOVE

### IMPORTANT NOTE!!

CERAMIC COALS AND LOGS GET VERY HOT! NEVER ATTEMPT TO HANDLE HOT COALS OR LOGS WITH BARE HANDS AND NEVER PLACE HOT COALS OR LOGS ON OR NEAR COMBUSTIBLE SURFACES.

NO RESPONSIBILITY FOR ANY INJURY HOWEVER CAUSED WHILST HANDLING HOT COALS, LOGS OR CERAMICS CAN BE ACCEPTED BY HUNTER STOVES LTD.



# FIRE-BED ARRANGEMENT

## FITTING THE CERAMIC MATRIX

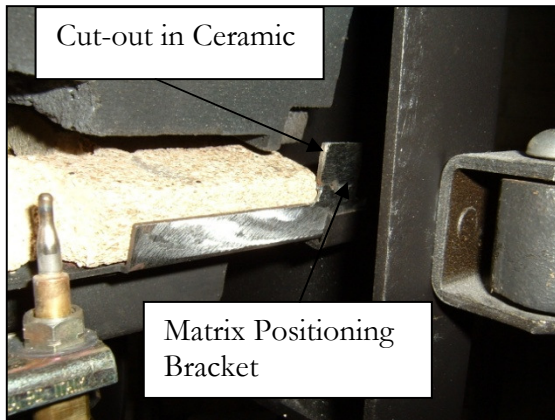

**Diagram 7**

Place the ceramic matrix onto the tray top, making sure that the cut-outs in both of the front bottom corners of the ceramic line up with the corresponding matrix positioning brackets on the tray top. This is shown in diagram 7.

Pull the Ceramic matrix forward so that the bracket fits into the hole, as described by diagram 8. Looking from above the matrix, make sure that the ceramic matrix does not cover the holes in the tray top. The spacing with the bracket should be central, and even either side. If you lift the matrix slightly the channels underneath should line up above the vertical slots in the burner tray.



**Diagram 8**

This appliance can be fitted with either 'coal effect' or 'log effect' ceramics.

If you are fitting 'Coal Effect' ceramics please follow the instructions set out in 'Section A – Fitting the Loose Ceramic Coals' - Page 10

If you are fitting 'Log Effect' ceramics please skip 'Section A' and follow the instructions set out in 'Section B – Fitting the Loose Ceramic Logs' - Page 12

## Section A - Fitting the Loose Ceramic Coals

### YOU SHOULD HAVE:

- 5 x Small Ceramic Coals
- 4 x Medium Ceramic Coals
- 2 x Large Diamond Ceramic Coals



**Diagram 9**

The first coals to be placed are the two 'Diamond' shaped coals. These should be placed in diamond shaped cut-outs as shown in diagram 9. Make sure that the coals **do not** block the flame port holes in the matrix.

The next coals to be placed are four of the medium coals. In a similar fashion to the coals already placed, these should be positioned around the flame port holes in the matrix as shown in diagram 10.



**Diagram 10**



**Diagram 11**

Finally the five small coals are located behind the existing row of coals, this time to each side of the rear holes in the matrix so that they rest on the back of the matrix. As shown in diagram 11.

The following page shows some larger pictures for clarity.







## Section B - Fitting the Loose Ceramic Logs

### YOU SHOULD HAVE:

- 1 x Y-Shaped Ceramic Log
- 1 x Small Branch Log
- 1 x 152x38 Single Branch
- 2 x 75x38 Very Small Branch Log
- 1 x Twig



The first log to be placed is the small branch log. This is placed around the left-hand front flame port hole in the matrix. The log should sit comfortably in place on the matrix as shown in diagram 12.

Diagram 12

The second log to be placed is the large 'Y-shaped' log. The single end of this log is positioned to the right of the second front flame port hole in the matrix, in the slot provided. The right hand fork at the opposite end of the log is then located in the cut-out on the top edge of the back of the ceramic matrix. The left hand fork should then rest on the edge of the matrix and the side of the stove. As shown in diagram 13.



Diagram 13



**Diagram 14**

The next to be placed is the single branch log that sits in a groove to the right of the 'Y' shaped log behind the third flame port hole in the matrix. The top of the log sits in the cut-out that is located on the top edge of the back of the ceramic matrix, as shown in diagram 14.

The fourth log is one of the very small branch logs and should be positioned behind the furthestmost right-hand flame port hole. The top of this should be rested against the back upright of the ceramic matrix, making sure that it is not directly above the rear flame port hole. This is shown in diagram 15.



**Diagram 15**



The next log is the second very small branch log that sits on the short arm of the 'Y' shaped log. The top of this sits in the cut-out on the rear upright at the back of the matrix. This is shown in diagram 16.

**Diagram 16**

The final log is a thin twig. This locates to the left of the furthestmost right hole in the matrix, the top resting on the straight log to the left of it. This and the complete log picture are shown in diagram 17.



**Diagram 17**



## FITTING THE CANOPY – (OPTIONAL)

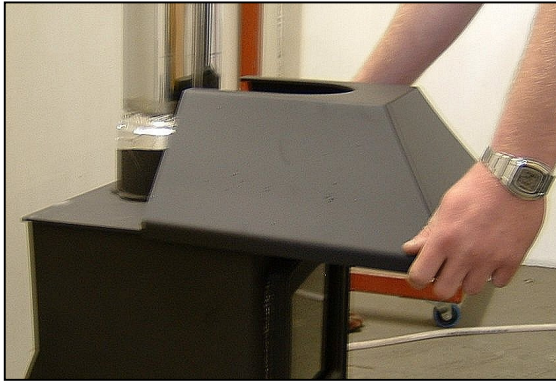

**Diagram 18**

There is an optional canopy available for the Hunter Hawk gas stove.

The canopy can be simply slid into place on the top plate of the stove body (Shown in diagram 18), making sure that the two welded tabs (located either side of the canopy) fit under the top plate.

The canopy is then secured in place by tightening the two fixing screws (one located either side of the canopy) with a flat-bladed screwdriver, shown in diagram 19.



**Diagram 19**

## TEST FOR SPILLAGE

A Spillage test **MUST** be made before the appliance is left with the customer.

Carry out the test by first closing all doors and windows in the room containing the fire.

The Ceramic Coal, or Log picture complete, the door sealed and handle replaced.

Ensure that the fire is burning at full rate for a minimum of 5 minutes.

Using a smoke match – run along the edge of the draught diverter, both sides of the TTB bracket (located at the rear of the stove), as shown in **diagram 20**.



Diagram 20

If most of the smoke is not drawn into the draught diverter leave for a further 10 minutes and repeat test.

If there is a fan in an adjoining room the spillage test must be repeated with the fan running and all connecting doors between the fire and fan open.

If there are still problems the chimney/flue may require attention.

## SPILLAGE MONITORING SYSTEM

The appliance is fitted with a thermostatic switch (TTB). This switch is located in the draught diverter and shuts off the gas supply should the flue lack sufficient flow to prevent flue gas spillage. The system **MUST NOT** be adjusted, changed or put out of action by the installer. The TTB **MUST NOT** be removed or 'bridged out' for any reason and only genuine Hunter Stoves replacements should be used. Nuisance shut down may occur if the stove is not installed in accordance with the clearance distances set out in page 5.

## OPERATING THE APPLIANCE

**FULL OPERATING INSTRUCTIONS ARE GIVEN IN THE USER INSTRUCTIONS.**



# **SERVICING INSTRUCTIONS**

It must be understood that any recommendations made here are in addition to the standard servicing procedures used by the servicing engineer.

1. A GAS SAFE registered fitter using only original Hunter Stoves parts should carry out servicing.
1. Open the stove door as described on Page 7.
2. Carefully lift-off the 'coals/logs' and remove the ceramic matrix.
3. Using a soft brush, clean away any lint or light carbon soot deposits out of the gas ports on the burner top plate.
4. Replace the ceramic matrix and loose 'coals/logs' as per the arrangement instructions (Page 9- Fire-bed Arrangement) using all re-serviceable 'coals/logs' and any new replacements.
5. Check the gas operating pressure and pipe work for soundness, carry out a spillage test and check the condition of the flue system.
6. If for any reason the TTB switch is removed or replaced during a service, we recommend wiping the mating surfaces clean and re-applying a thin smear of 150°C Heat Sink Compound to the face of the TTB.

## SPARES LIST

| PART DESCRIPTION                 | PART NUMBER |
|----------------------------------|-------------|
| TTB Set                          |             |
| TTB Switch                       | HG06/200    |
| TTB Leads                        | HG06/201    |
|                                  |             |
| Natural Gas Burner Injector      | HGH/028     |
|                                  |             |
| Control Valve                    | HGH/045     |
|                                  |             |
| Glass Panel (D Type Door)        | HCR06/058   |
| Glass Panel (Standard Door)      | HCR06/039   |
| Glass Clip + Screw               | HHR08/046   |
|                                  |             |
| Door Rope Kit (D Type Door)      | SCPHKDRSK   |
| Door Rope Kit (Standard Door)    | SCPHKRSK    |
|                                  |             |
| Natural Gas Pilot Assembly       | HGH/030     |
|                                  |             |
| <b>Ceramic Spares</b>            |             |
| Vermiculite – Tray Top           | HGH/023     |
|                                  |             |
| Ceramic Matrix – 1 Piece         | HGH/024     |
|                                  |             |
| Small Ceramic Coal               | HG06/044    |
| Medium Ceramic Coal              | HG06/045    |
| Large Diamond Ceramic Coal       | HG06/046    |
|                                  |             |
| Log 1 – ‘Y – Shaped’ Ceramic Log | HG06/074    |
| Log 2 – Small branch log         | HG06/075    |
| Log 5 – 152x38 Single Branch     | HG06/078    |
| 75x38 Very Small Branch Log      | HGH/029     |
| Log 6 – ‘Twig’                   | HG06/079    |
|                                  |             |



Aspen House, Pynes Hill, Exeter, EX2 5AZ  
[www.hunterstoves.co.uk](http://www.hunterstoves.co.uk)